





 Porto Alegre - RS
+55 51 99676-0121

 Sorriso - MT
+55 66 99931-1198

 Barreiras - BA
+55 77 99941-4048

 Pensacola - FL
+1 850 972-9096

INTEGRAÇÃO TOTAL
DGPS + SOFTWARE + CLIMA + QUALIDADE



CATÁLOGO DE PARTES BOMBA EÓLICA INOX AIR TRACTOR THRUSH

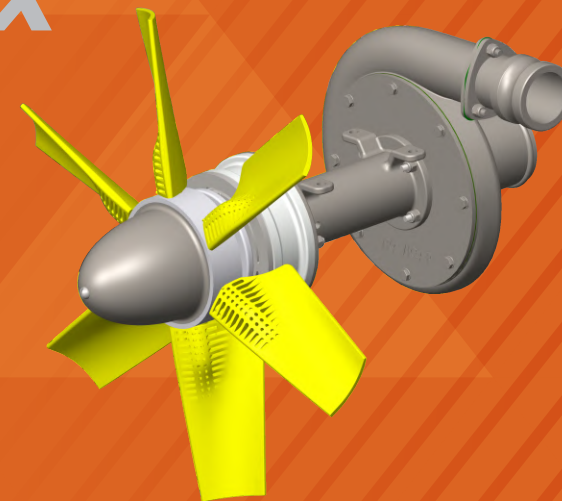

SUA AERONAVE 100% TRAVICAR

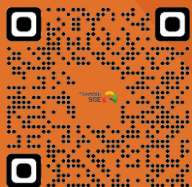

TRAVICAR
SGE

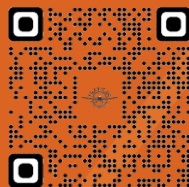

WEBSITE
TRAVICAR

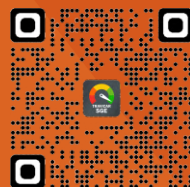

TRAVICAR
APP

Catálogo de Peças de Reposição

www.travicar.com.br

EQUIPAMENTO AGRÍCOLA

BOMBA EÓLICA INOX

SUMÁRIO BOMBA EÓLICA



Porto Alegre - RS
+55 51 99676-0121



Sorriso - MT
+55 66 99931-1198



Barreiras - BA
+55 77 99941-4048



Pensacola - FL
+1 850 972-9096



BOMBA EÓLICA

20811 - FREIO 120mm

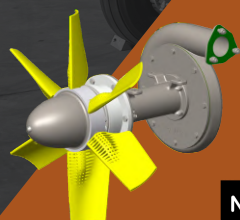

NEW

PÁGINA 3

BOMBA EÓLICA

20814 - FREIO 135mm

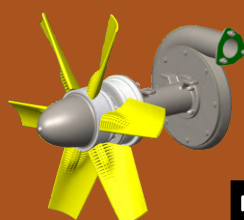

NEW

PÁGINA 5

BOMBA EÓLICA

20812 - FREIO DE 160mm

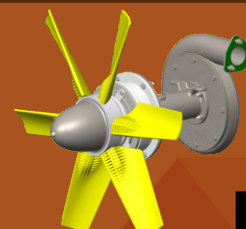

NEW

PÁGINA 7

BOMBA EÓLICA

20808G / 05033G - FREIO DE 120mm

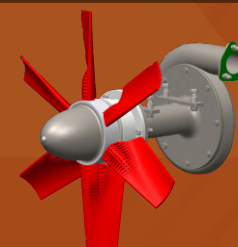

PÁGINA 9

BOMBA EÓLICA

20808G / 05033G - FREIO DE 160mm

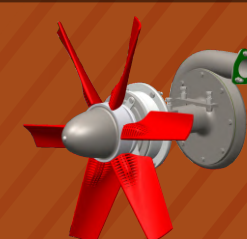

PÁGINA 11

BOMBA EÓLICA

20808G/05033G - FREIO ANTIGO

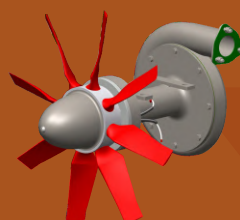

PÁGINA 13

BOMBA EÓLICA

20808P/05033P - FREIO ANTIGO



PÁGINA 15

FREIOS E ROTORES

FREIOS E ROTORES

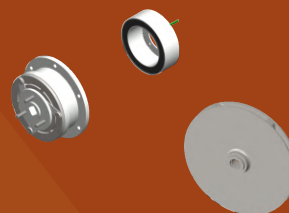

PÁGINA 17

CUBOS E PÁS

CUBOS E PÁS DE HÉLICE

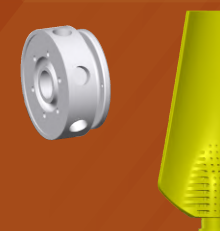

PÁGINA 21

FLANGES E SUPORTES

FLANGES E SUPORTES



PÁGINA 23



EQUIPAMENTO AGRÍCOLA

BOMBA EÓLICA INOX

SELEÇÃO BOMBA EÓLICA



Porto Alegre - RS
+55 51 99676-0121



Sorriso - MT
+55 66 99931-1198



Barreiras - BA
+55 77 99941-4048



Pensacola - FL
+1 850 972-9096

Evolução dos Modelos de Bombas Eólicas TRAVICAR

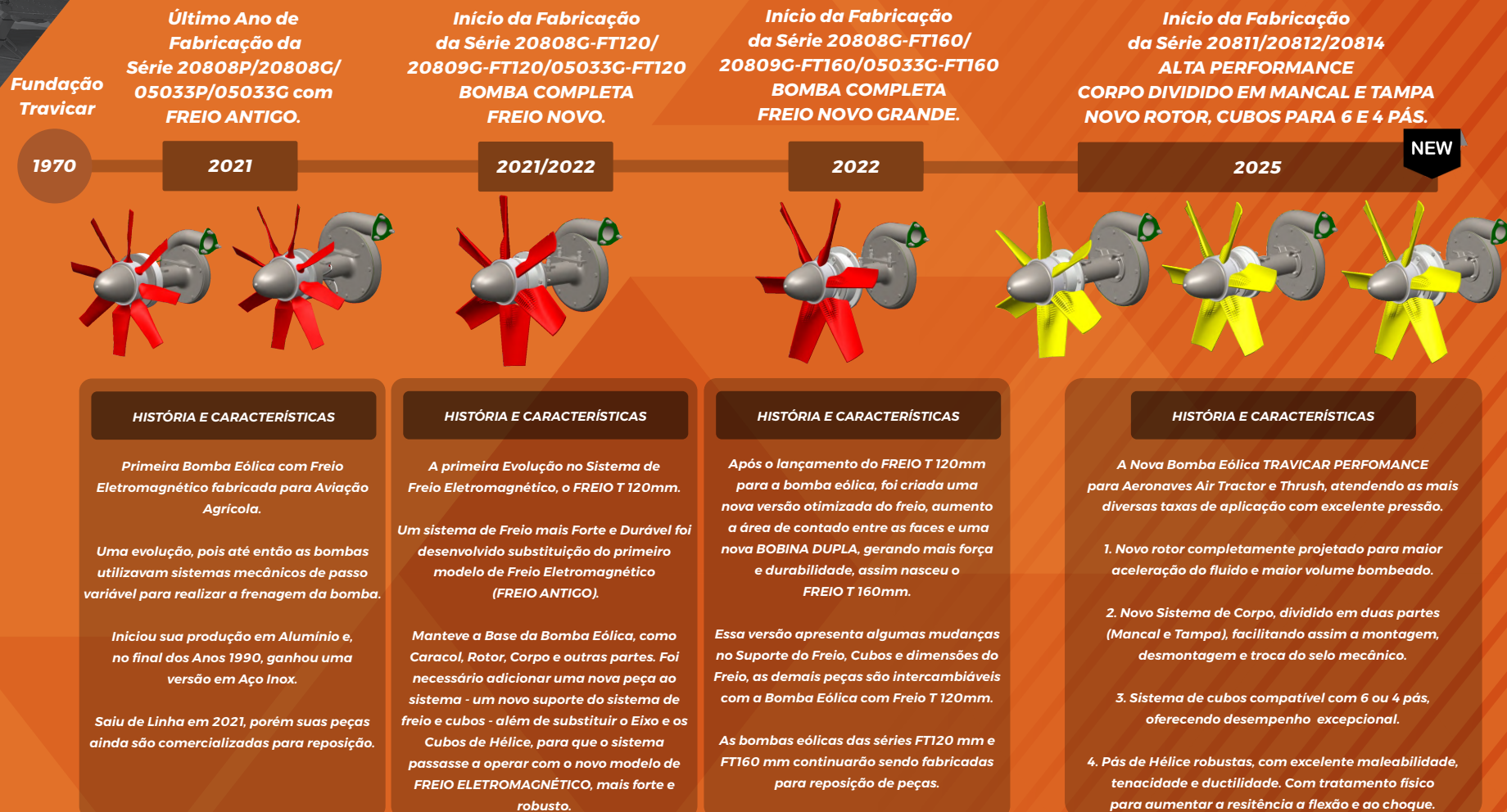

EQUIPAMENTO AGRÍCOLA

BOMBA EÓLICA INOX

SELEÇÃO BOMBA EÓLICA



Porto Alegre - RS
+55 51 99676-0121



Sorriso - MT
+55 66 99931-1198



Barreiras - BA
+55 77 99941-4048



Pensacola - FL
+1 850 972-9096

Como escolher a Bomba Eólica ideal para sua operação.

20811 - FREIO 120mm

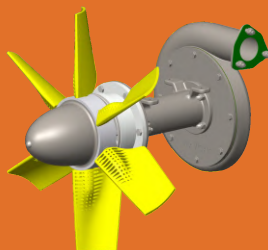

INFORMAÇÕES

A bomba eólica 20811 é um modelo projetado para alta durabilidade e baixo esforço mecânico. Possui cubo e pás com três pitches, operando com eficiência em taxas de até 35 L/ha. Utiliza pás de 140 ou 165 mm, Rotor Performance e Corpo em duas partes com mancal e tampa. Suas pás são espessas, fortes e flexíveis, garantindo resistência a choques e longa vida útil. Atende cerca de 95% das operações agrícolas no Brasil e é indicada para aeronaves Air Tractor (402, 502, 602, 802) e Thrush 510.

Freio 120mm
Cubos de Hélice: 3 Posições
Pás: 140mm ou 165mm

EQUILÍBRIO E SUAVIDADE

20814 - FREIO 135mm

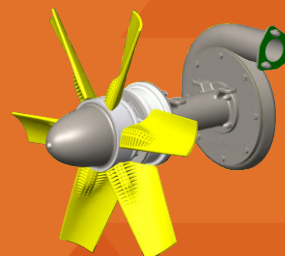

INFORMAÇÕES

A bomba eólica 20814 representa uma evolução no sistema de freio, com aumento da área de contato das faces e utilização de bobina dupla, resultando em um freio mais forte, robusto e eficiente. Esse conjunto permite que a bomba opere com rotação e torque mais elevados, viabilizando o uso de cubo de hélice com 6 posições de pitch e pás de hélice maiores. Com isso, a bomba eólica 20814 alcança taxas de aplicação superiores a 50 L/ha, mantendo alta capacidade de frenagem, segurança operacional e confiabilidade.

Freio 135mm
Cubos de Hélice: 5 Posições
Pás: 165mm ou 195mm

EQUILÍBRIO E FORÇA

20812 - FREIO 160mm

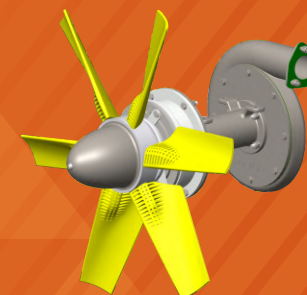

INFORMAÇÕES

A bomba eólica 20814 representa uma evolução no sistema de freio, com aumento da área de contato das faces e utilização de bobina dupla, resultando em um freio mais forte, robusto e eficiente. Esse conjunto permite que a bomba opere com rotação e torque mais elevados, viabilizando o uso de cubo de hélice com 6 posições de pitch e pás de hélice maiores. Com isso, a bomba eólica 20814 alcança taxas de aplicação superiores a 50 L/ha, mantendo alta capacidade de frenagem, segurança operacional e confiabilidade.

Freio 160mm
Cubos de Hélice: 5 Posições
Pás: 165mm ou 195mm

EQUILÍBRIO E MUITA FORÇA



EQUIPAMENTO AGRÍCOLA

NEW

BOMBA EÓLICA 20811 INOX

BOMBA EÓLICA



Porto Alegre - RS
+55 51 99676-0121



Sorriso - MT
+55 66 99931-1198



Barreiras - BA
+55 77 99941-4048



Pensacola - FL
+1 850 972-9096

BOMBA EÓLICA INOX 20811 - FREIO 120mm

EIXO 25mm

ROTOR
PERFORMANCE

EQUILÍBRIO
E DURABILIDADE

6P



AIR TRACTOR 402/502
20811-402/502-X-6P

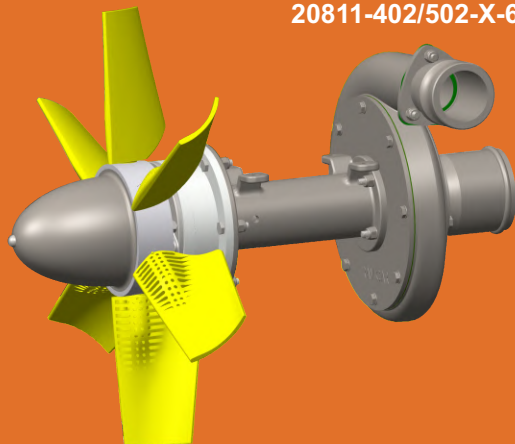

THRUSH 510
20811-510-X-6P

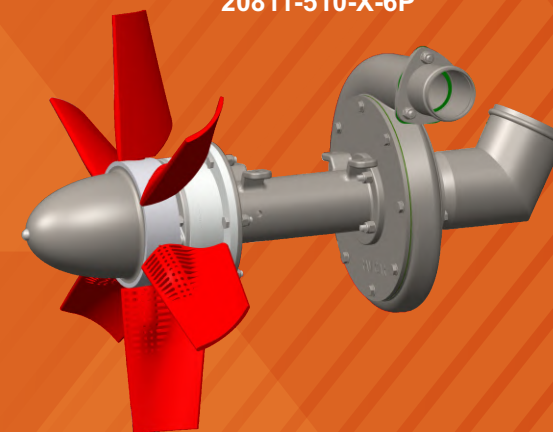

AIR TRACTOR 602/802
20811-602/802-X-6P

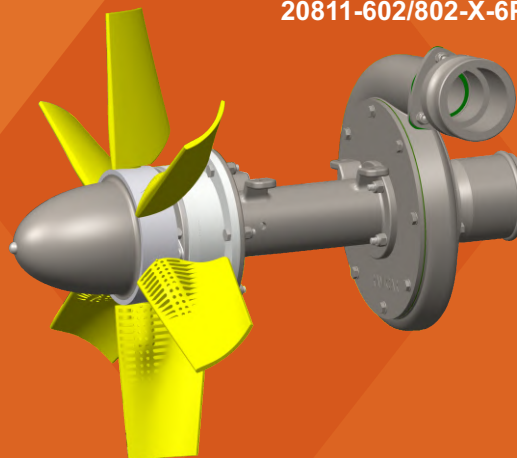

FORMAÇÃO BASE



CUBO DE HÉLICE COM 3 POSIÇÕES (PITCH)

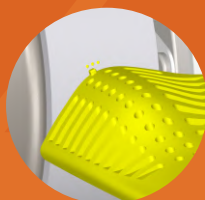

INFORMAÇÕES

Cubo de Hélice: 6 pás.

Passo Cubo de Hélice: 3 posições.

Comprimento Pás: 140mm ou 165mm.

Taxa de Aplicação Projetada: Até 35 l/ha

Equilíbrio entre durabilidade
e Performance.

Sistema de Freio Indireto de
120mm x 145mm.

Eixo: Quadrado de 1" com Rosca 5/8".

Selo Mecânico: Silício (Padrão)
ou Tungstênio.



EQUIPAMENTO AGRÍCOLA

NEW

BOMBA EÓLICA 20811 INOX

BOMBA EÓLICA

Porto Alegre - RS
+55 51 99676-0121

Sorriso - MT
+55 66 99931-1198

Barreiras - BA
+55 77 99941-4048

Pensacola - FL
+1 850 972-9096

BOMBA EÓLICA INOX 20811 - FREIO 120mm

EIXO 25mm
ROTOR
PERFORMANCE
EQUILÍBRIO
E DURABILIDADE

6P

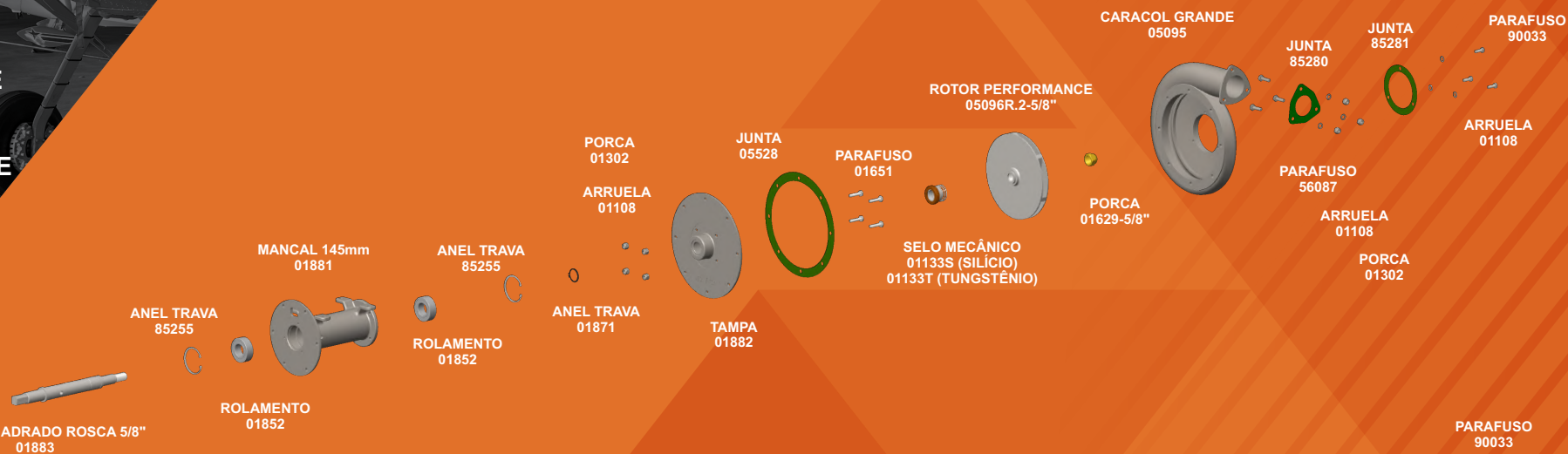

EIXO 1" QUADRADO ROSCA 5/8"
01883

ANEL TRAVA
85255

MANCAL 145mm
01881

ANEL TRAVA
85255

ROLAMENTO
01852

ANEL TRAVA
01871

ARRUELA
01108

PORCA
01302

JUNTA
05528

TAMPA
01882

PARAFUSO
01651

SELO MECÂNICO
01133S (SILÍCIO)
01133T (TUNGSTÊNIO)

ROTOR PERFORMANCE
05096R.2-5/8"

PORCA
01629-5/8"

CARACOL GRANDE
05095

PARAFUSO
56087

ARRUELA
01108

PORCA
01302

JUNTA
85281

ARRUELA
01108

PARAFUSO
90033

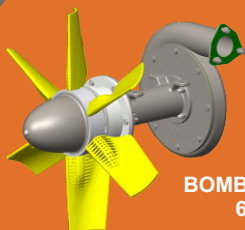

BOMBA EÓLICA
6 PÁS

PARAFUSO
01763

SPINNER
01084

PARAFUSO
01460

ARRUELA
01108

SUPORTE SPINNER
01352-T

CUBOS (PITCH 3)
05138

PÁ DE HÉLICE

01065 (145mm VERMELHO)
01065-A (145mm AMARELO)
01065-P 01065 (145mm PRETO)
01070 (165mm VERMELHO)
01070-A (165mm AMARELO)
01070-P (165mm PRETO)

PORCA
01302

CUBOS (PITCH 3)
05138

ARRUELA
56051

PARAFUSO
09072

PARAFUSO
01651

PORCA
01302

ARRUELA
01108

FREIO 120mm x 145mm
01855-G

PARAFUSO
56090

BOBINA
01851-24V

REPARO BOMBA EÓLICA
05174



Alguns itens são comercializados apenas através do kit reparo.



EQUIPAMENTO AGRÍCOLA

NEW

BOMBA EÓLICA 20814 INOX

BOMBA EÓLICA



Porto Alegre - RS
+55 51 99676-0121



Sorriso - MT
+55 66 99931-1198



Barreiras - BA
+55 77 99941-4048



Pensacola - FL
+1 850 972-9096

BOMBA EÓLICA INOX 20814 - FREIO 135mm

AIR TRACTOR 402/502
20814-402/502-X-6P
20814-402/502-X-4P

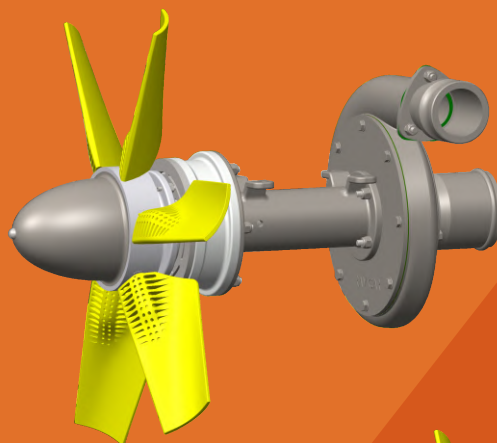

THRUSH 510
20814-510-X-6P
20814-510-X-4P

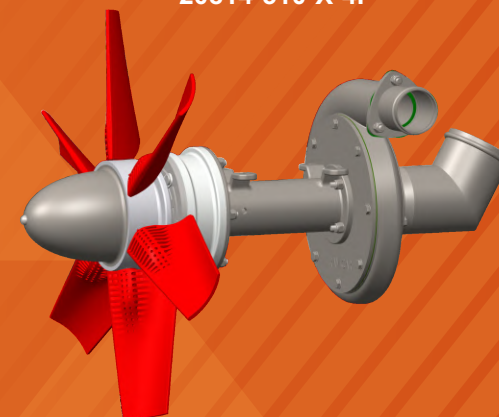

AIR TRACTOR 602/802
20814-602/802-X-6P
20814-602/802-X-4P

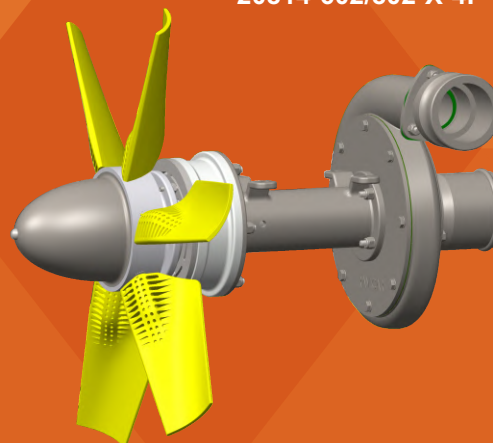

6P/4P

EIXO 25mm

ROTOR
PERFORMANCE

FRENAGEM
REFORÇADA



INFORMAÇÕES

Cubo de Hélice: 4 ou 6 pás.

Passo Cubo de Hélice: 6 posições.

Comprimento Pás: 165mm ou 195mm.

Taxa de Aplicação Projetada: 50 l/ha
ou mais.

Performance e Segurança para Taxas
de Aplicação mais Altas.

Sistema de Freio Indireto de
135mm x 145mm.

Eixo: Quadrado de 1" com Rosca 5/8".

Selo Mecânico: Silício (Padrão)
ou Tungstênio.

CUBO DE HÉLICE COM 6 POSIÇÕES (PITCH)



FORMAÇÃO BASE





EQUIPAMENTO AGRÍCOLA

NEW

BOMBA EÓLICA 20814 INOX

BOMBA EÓLICA

Porto Alegre - RS
+55 51 99676-0121

Sorriso - MT
+55 66 99931-1198

Barreiras - BA
+55 77 99941-4048

Pensacola - FL
+1 850 972-9096

BOMBA EÓLICA INOX 20814 - FREIO 135mm

EIXO 25mm

ROTOR
PERFORMANCE

FRENAGEM
REFORÇADA

6P/4P

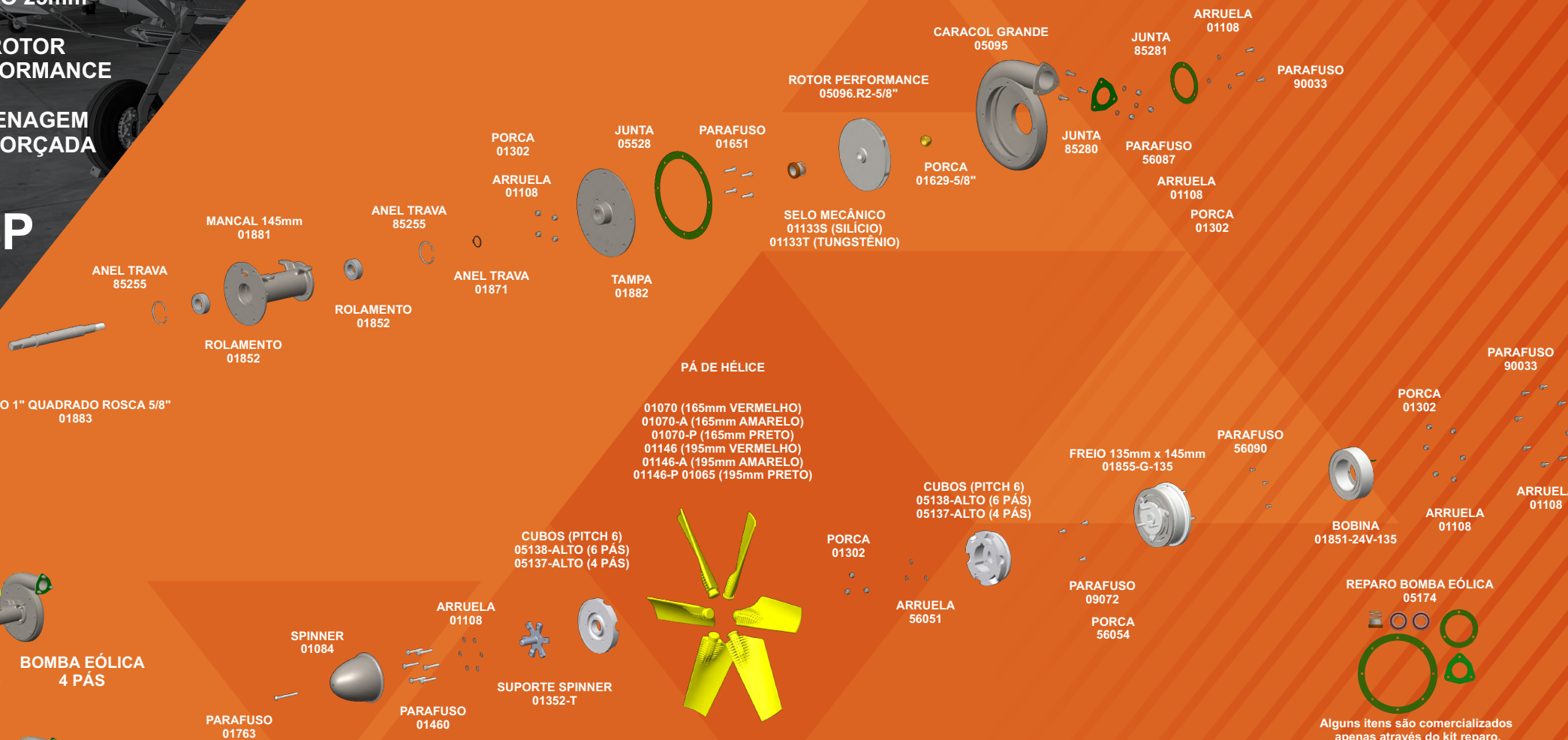

Alguns itens são comercializados apenas através do kit reparo.



EQUIPAMENTO AGRÍCOLA

NEW

BOMBA EÓLICA 20812 INOX

BOMBA EÓLICA

 Porto Alegre - RS
+55 51 99676-0121

 Sorriso - MT
+55 66 99931-1198

 Barreiras - BA
+55 77 99941-4048

 Pensacola - FL
+1 850 972-9096

BOMBA EÓLICA INOX 20812 - FREIO 160mm

EIXO 25mm

ROTOR
PERFORMANCE

FRENAGEM
EXTREMA

6P/4P

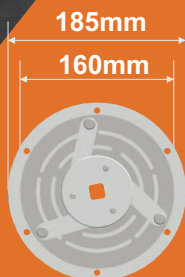

AIR TRACTOR 402/502
20812-402/502-X-6P
20812-402/502-X-4P



AIR TRACTOR 602/802
20812-602/802-X-6P
20812-602/802-X-4P

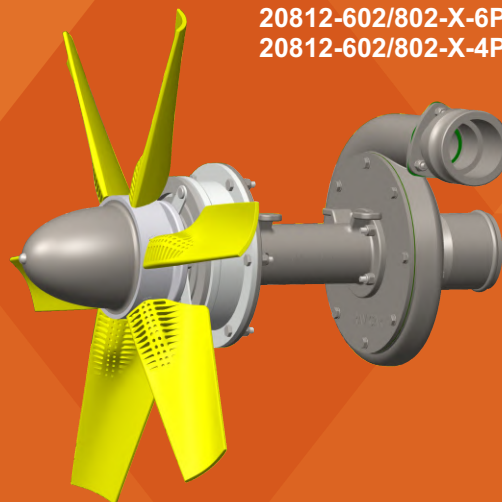

THRUSH 510
20812-510-X-6P
20812-510-X-4P

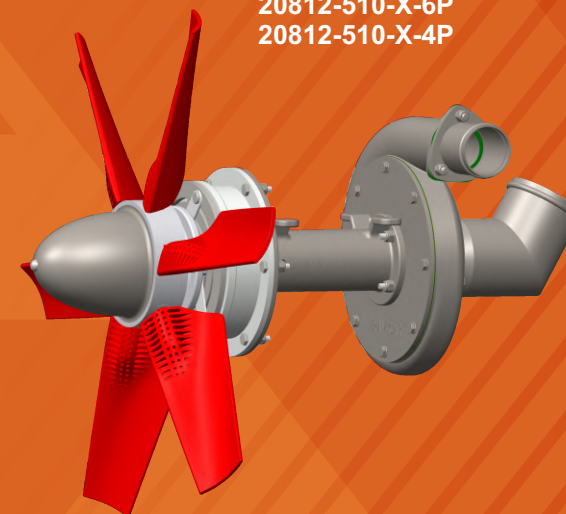

INFORMAÇÕES

Cubo de Hélice: 4 ou 6 pás.

Passo Cubo de Hélice: 6 posições.

Comprimento Pás: 165mm ou 195mm.

Taxa de Aplicação Projetada: 50 l/ha
ou mais.

Performance e Segurança para Taxas
de Aplicação mais Altas para
Aeronaves Muito Rápidas.

Sistema de Freio Indireto de
160mm x 185mm.

Eixo: Quadrado de 1" com Rosca 5/8".

Selo Mecânico: Silício (Padrão)
ou Tungstênio.

CUBO DE HÉLICE COM 6 POSIÇÕES (PITCH)



FORMAÇÃO BASE



www.travicar.com.br

09



EQUIPAMENTO AGRÍCOLA

NEW

BOMBA EÓLICA 20814 INOX

BOMBA EÓLICA



Porto Alegre - RS
+55 51 99676-0121



Sorriso - MT
+55 66 99931-1198



Barreiras - BA
+55 77 99941-4048



Pensacola - FL
+1 850 972-9096

BOMBA EÓLICA INOX 20812 - FREIO 160mm

EIXO 25mm

ROTOR
PERFORMANCE

FRENAGEM
EXTREMA

6P/4P

EIXO 1" QUADRADO ROSCA 5/8"
01883

ANEL TRAVA
85255

MANCAL 185mm
01881-160

ANEL TRAVA
85255

PORCA
01302

ARRUELA
01108

ANEL TRAVA
01871

ROLAMENTO
01852

ROLAMENTO
01852

JUNTA
05528

PARAFUSO
01651

TAMPA
01882

ROTOR PERFORMANCE
05096.R2-5/8"

SELO MECÂNICO
01133S (SILÍCIO)
01133T (TUNGSTÊNIO)

PORCA
01629-5/8"

CARACOL GRANDE
05095

PARAFUSO
56087

JUNTA
85280

JUNTA
85281

ARRUELA
01108

PARAFUSO
90033

ARRUELA
01108

PORCA
01302

PARAFUSO
90033

PARAFUSO
56090

PARAFUSO
01651

PORCA
56054

CUBOS (PITCH 6)
05138-ALTO (6 PÁS)
05137-ALTO (4 PÁS)

PORCA
01302

PARAFUSO
09072

ARRUELA
56051

ARRUELA
01108

FREIO 160mm x 185mm
01855-G-160

BOBINA
01851-24V-160

ARRUELA
01108

CUBOS (PITCH 6)
05138-ALTO (6 PÁS)
05137-ALTO (4 PÁS)

ARRUELA
01108

SPINNER
01084

PARAFUSO
01460

SUPORTE SPINNER
01352-T

PARAFUSO
01763

PÁ DE HÉLICE

01070 (165mm VERMELHO)
01070-A (165mm AMARELO)
01070-P (165mm PRETO)
01146 (195mm VERMELHO)
01146-A (195mm AMARELO)
01146-P 01065 (195mm PRETO)

REPARO BOMBA EÓLICA
05174

Alguns itens são comercializados apenas através do kit reparo.



EQUIPAMENTO AGRÍCOLA

BOMBA EÓLICA 20808G / 20809G / 05033G INOX

BOMBA EÓLICA



Porto Alegre - RS
+55 51 99676-0121



Sorriso - MT
+55 66 99931-1198



Barreiras - BA
+55 77 99941-4048



Pensacola - FL
+1 850 972-9096

BOMBA EÓLICA INOX 20808G-FT120 / 20809G-FT120 / 05033G-FT120 - FREIO 120mm

AIR TRACTOR 402/502
20808G-FT120-402/502-X-6P

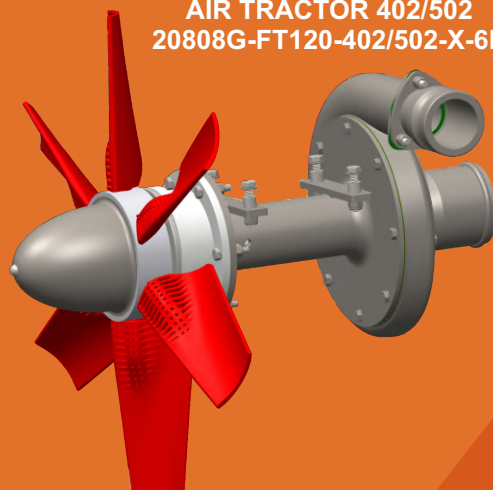

THRUSH 510
05033G-FT120-510-X-6P

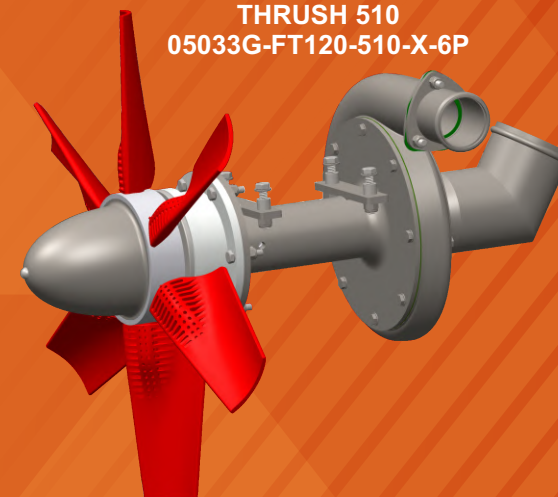

AIR TRACTOR 602/802
20809G-FT120-602/802-X-6P

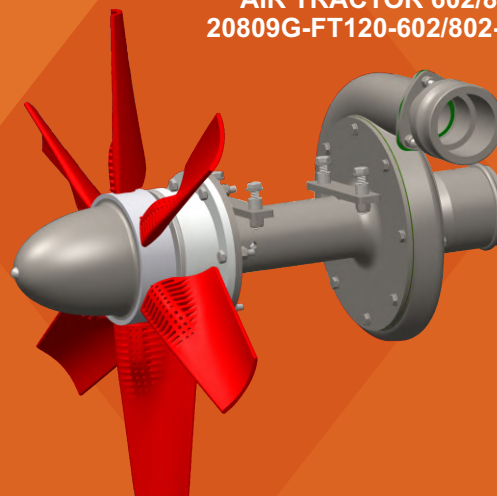

INFORMAÇÕES

Cubo de Hélice: 6 pás.

Passo Cubo de Hélice: 3 posições.

Comprimento Pás: 140mm ou 165mm.

Taxa de Aplicação Projetada: Até 35 l/ha

Equilíbrio entre durabilidade e Performance.

Sistema de Freio Indireto de 120mm x 145mm.

Eixo: Quadrado de 1" com Rosca 5/8".

Selo Mecânico: Silício (Padrão) ou Tungstênio.

CUBO DE HÉLICE COM 3 POSIÇÕES (PITCH)

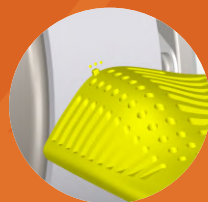

FORMAÇÃO BASE





EQUIPAMENTO AGRÍCOLA

BOMBA EÓLICA 20808G / 20809G / 05033G INOX

BOMBA EÓLICA



Porto Alegre - RS
+55 51 99676-0121



Sorriso - MT
+55 66 99931-1198



Barreiras - BA
+55 77 99941-4048



Pensacola - FL
+1 850 972-9096

BOMBA EÓLICA INOX 20808G-FT120 / 20809G-FT120 / 05033G-FT120 - FREIO 120mm



BOMBA EÓLICA
6 PÁS

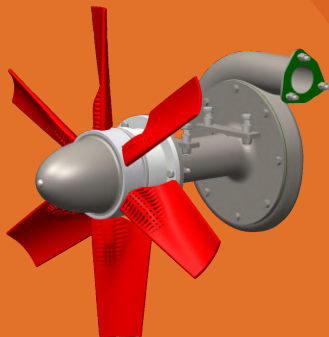

Alguns itens são comercializados apenas através do kit reparo.



EQUIPAMENTO AGRÍCOLA

BOMBA EÓLICA 20808G / 20809G / 05033G INOX

BOMBA EÓLICA

 Porto Alegre - RS
+55 51 99676-0121

 Sorriso - MT
+55 66 99931-1198

 Barreiras - BA
+55 77 99941-4048

 Pensacola - FL
+1 850 972-9096

**FRENAGEM
EXTREMA**

BOMBA EÓLICA INOX 20808G-FT160 / 20809G-FT160 / 05033G-FT160 - FREIO 160mm

AIR TRACTOR 402/502
20808G-FT160-402/502-X-6P
20808G-FT160-402/502-X-4P

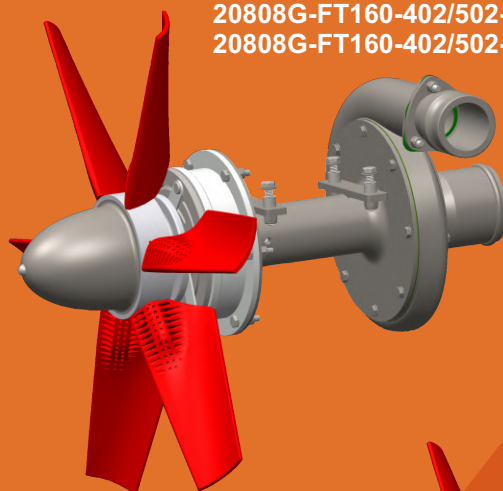

THRUSH 510
05033G-FT160-510-X-6P
05033G-FT160-510-X-4P

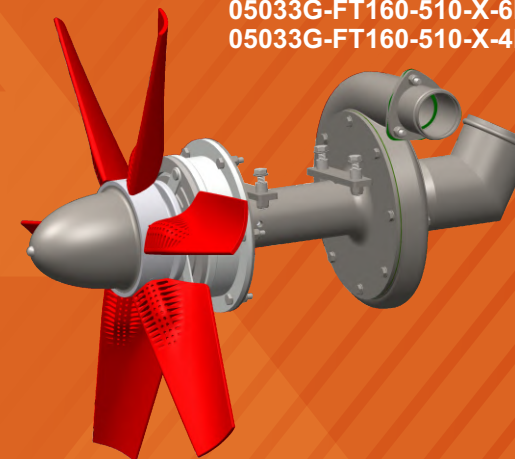

AIR TRACTOR 602/802
20809G-FT160-602/802-X-6P
20809G-FT160-602/802-X-4P

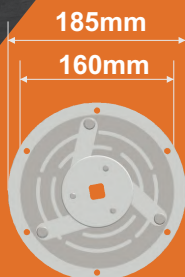
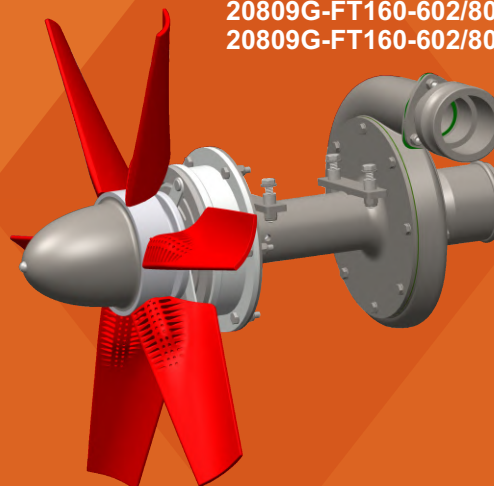

INFORMAÇÕES

Cubo de Hélice: 4 ou 6 pás.

Passo Cubo de Hélice: 6 posições.

Comprimento Pás: 165mm ou 195mm.

Taxa de Aplicação Projetada: 50 l/ha ou mais.

Performance e Segurança para Taxas de Aplicação mais Altas para Aeronaves Muito Rápidas.

Sistema de Freio Indireto de 160mm x 185mm.

Eixo: Quadrado de 1" com Rosca 5/8".

Selo Mecânico: Silício (Padrão) ou Tungstênio.

CUBO DE HÉLICE COM 6 POSIÇÕES (PITCH)



FORMAÇÃO BASE

SUPORTE DO FREIO 185mm

ROTOR

FREIO 160mm

CORPO INTEIRO

www.travicar.com.br

13



EQUIPAMENTO AGRÍCOLA

BOMBA EÓLICA 20808G / 20809G / 05033G INOX

BOMBA EÓLICA



Porto Alegre - RS
+55 51 99676-0121



Sorriso - MT
+55 66 99931-1198



Barreiras - BA
+55 77 99941-4048



Pensacola - FL
+1 850 972-9096

BOMBA EÓLICA INOX 20808G-FT160 / 20809G-FT160 / 05033G-FT160 - FREIO 160mm



BOMBA EÓLICA 6 PÁS

Alguns itens são comercializados apenas através do kit reparo.



EQUIPAMENTO AGRÍCOLA

BOMBA EÓLICA 20808P / 05033P INOX

BOMBA EÓLICA



Porto Alegre - RS
+55 51 99676-0121



Sorriso - MT
+55 66 99931-1198



Barreiras - BA
+55 77 99941-4048



Pensacola - FL
+1 850 972-9096

BOMBA EÓLICA INOX 20808P-FA / 05033P-FA - FREIO ANTIGO

**FREIO
ANTIGO**

AIR TRACTOR 402/502
20808P-FA-402/502-X-8P

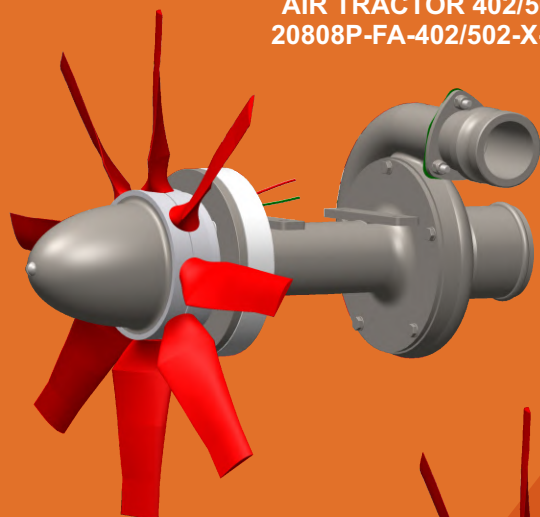

THRUSH 510
05033P-FA-510-X-8P

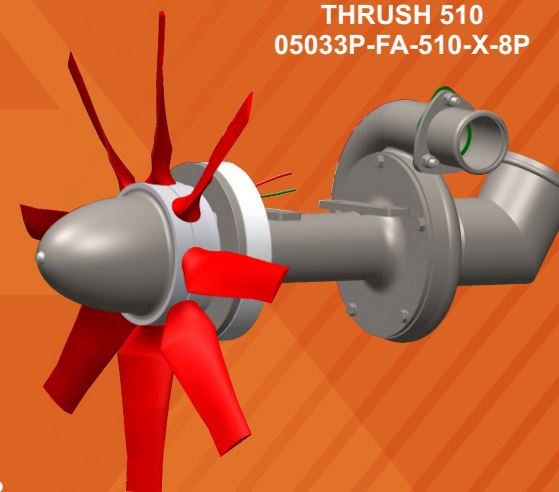

AIR TRACTOR 602/802
20808P-FA-602/802-X-8P

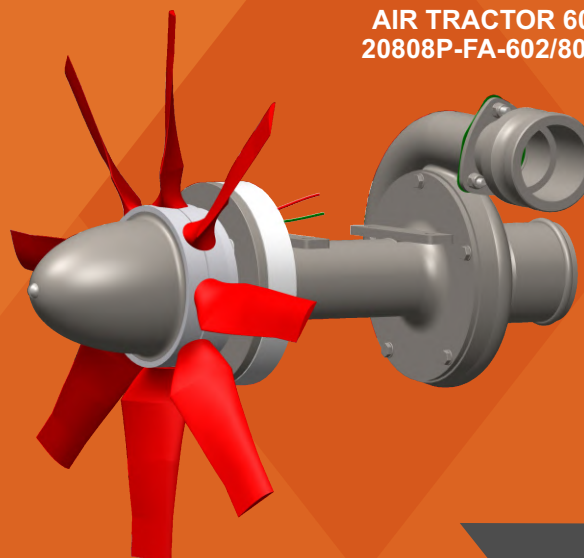

PRODUTO DESCONTINUADO,
APENAS PEÇAS DE REPOSIÇÃO.

INFORMAÇÕES

Cubo de Hélice: 8 pás.

Comprimento Pás: 147mm.

Sistema de Freio Direto
(ANTIGO)

Eixo: Rosca 5/8", 20mm com Rosca 1/2".

Selo Mecânico: Silício (Padrão)
ou Tungstênio.

FORMAÇÃO BASE

FREIO DIRETO 24V

DISCO FLUTUANTE

CORPO INTEIRO

ROTOR

www.travicar.com.br

15



EQUIPAMENTO AGRÍCOLA

BOMBA EÓLICA 20808P / 05033P INOX

BOMBA EÓLICA



Porto Alegre - RS
+55 51 99676-0121



Sorriso - MT
+55 66 99931-1198



Barreiras - BA
+55 77 99941-4048



Pensacola - FL
+1 850 972-9096

BOMBA EÓLICA INOX 20808P-FA / 05033P-FA - FREIO ANTIGO

PRODUTO DESCONTINUADO,
APENAS PEÇAS DE REPOSIÇÃO.

**FREIO
ANTIGO**



**BOMBA EÓLICA
8 PÁS**



Alguns itens são comercializados
apenas através do kit reparo.



EQUIPAMENTO AGRÍCOLA

BOMBA EÓLICA 20808G / 05033G INOX

BOMBA EÓLICA



Porto Alegre - RS
+55 51 99676-0121



Sorriso - MT
+55 66 99931-1198



Barreiras - BA
+55 77 99941-4048



Pensacola - FL
+1 850 972-9096

BOMBA EÓLICA INOX 20808G-FA / 05033G-FA - FREIO ANTIGO

**FREIO
ANTIGO**

**AIR TRACTOR 402/502
20808G-FA-402/502-X-8P**

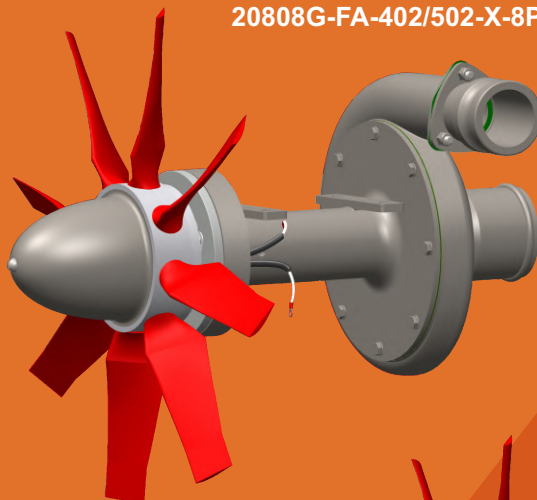

**THRUSH 510
05033G-FA-510-X-8P**

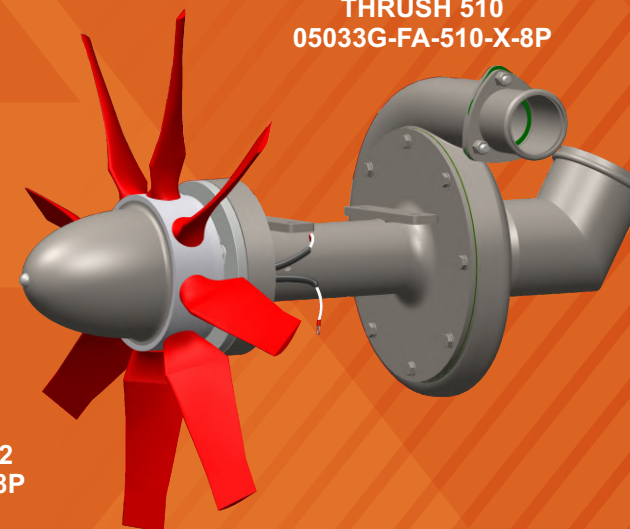

**AIR TRACTOR 602/802
20808G-FA-602/802-X-8P**

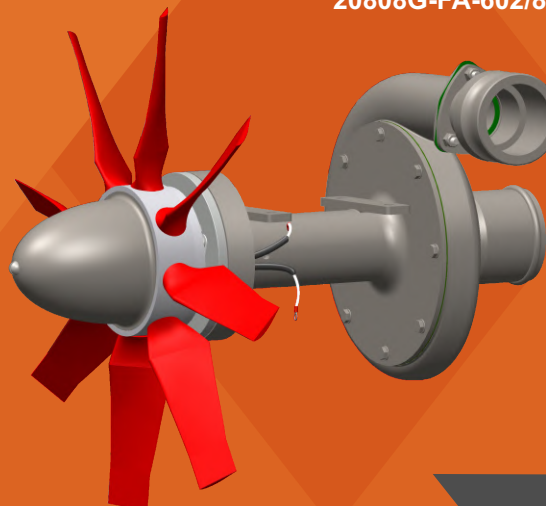

**PRODUTO DESCONTINUADO,
APENAS PEÇAS DE REPOSIÇÃO.**

INFORMAÇÕES

Cubo de Hélice: 8 pás.

Comprimento Pás: 147mm.

Sistema de Freio Direto
(ANTIGO)

Eixo: Rosca 5/8", 20mm com Rosca 1/2".

Selo Mecânico: Silício (Padrão)
ou Tungstênio.

FORMAÇÃO BASE

FREIO DIRETO 24V

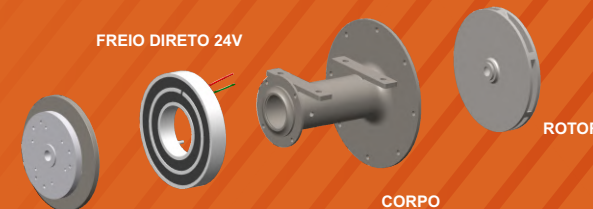

DISCO FLUTUANTE

CORPO
INTEIRO

ROTOR

www.travicar.com.br

17



EQUIPAMENTO AGRÍCOLA

FREIOS ELETROMAGNÉTICOS

BOMBA EÓLICA



Porto Alegre - RS
+55 51 99676-0121



Sorriso - MT
+55 66 99931-1198



Barreiras - BA
+55 77 99941-4048



Pensacola - FL
+1 850 972-9096

FREIOS ELETROMAGNÉTICOS PARA EIXOS QUADRADOS

EIXOS COMPATÍVEIS

EIXO BOMBA AT-TH
01850
01856

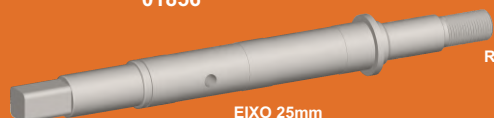

ROSCA 5/8"

EIXO 25mm

QUADRADO
16mm X 16mm

FREIO 120mm x 145mm
01855-G



BOBINA
01851-24V

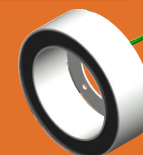

BOBINA
01851-24V-135

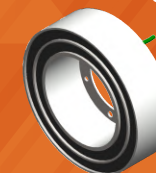

BOBINA
01851-24V-160



FREIO 135mm x 145mm
01855-G-135



FREIO 160mm x 185mm
01855-G-160



DETALHES

FREIO 120mm x 145mm
01855-G



Sistema de Freio
de Entrada.

FREIO 135mm x 145mm
01855-G-135



Sistema de Freio
Intermediário.

FREIO 160mm x 185mm
01855-G-160

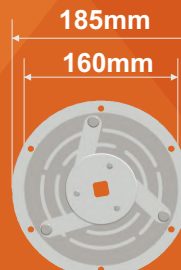

Sistema de Freio
Alta Performance.



EQUIPAMENTO AGRÍCOLA

FREIOS ELETROMAGNÉTICOS

BOMBA EÓLICA



Porto Alegre - RS
+55 51 99676-0121



Sorriso - MT
+55 66 99931-1198



Barreiras - BA
+55 77 99941-4048



Pensacola - FL
+1 850 972-9096

FREIOS ELETROMAGNÉTICOS PARA EIXOS QUADRADOS

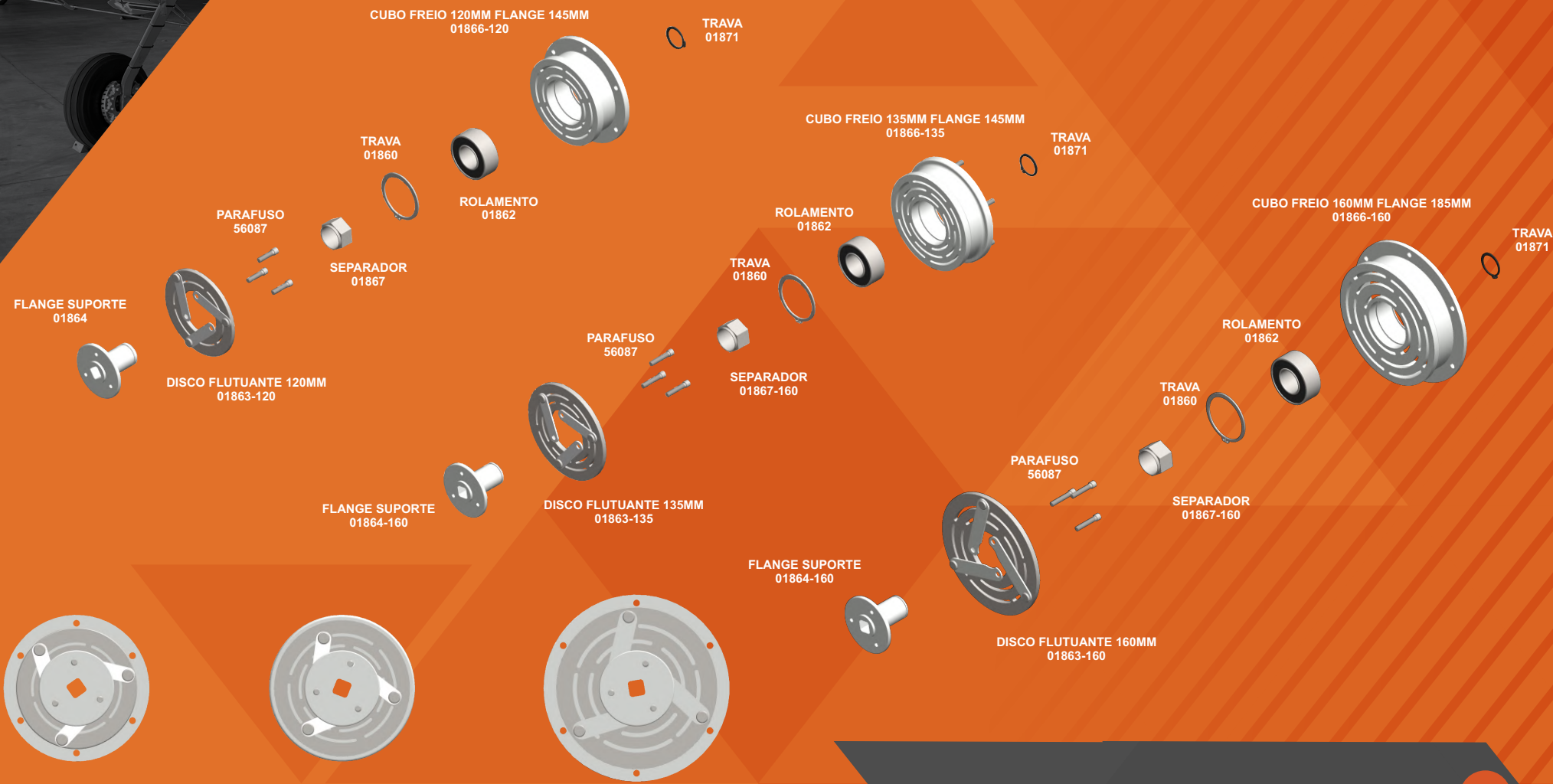

FREIO 120mm x 145mm
01855-G

FREIO 135mm x 145mm
01855-G-135

FREIO 160mm x 185mm
01855-G-160



EQUIPAMENTO AGRÍCOLA

FREIOS ELETROMAGNÉTICOS

BOMBA EÓLICA



Porto Alegre - RS
+55 51 99676-0121



Sorriso - MT
+55 66 99931-1198



Barreiras - BA
+55 77 99941-4048



Pensacola - FL
+1 850 972-9096

FREIOS ELETROMAGNÉTICOS PARA BOMBAS ANTIGAS

PRODUTO DESCONTINUADO,
APENAS PEÇAS DE REPOSIÇÃO.

DISCO FLUTUANTE
01252-2

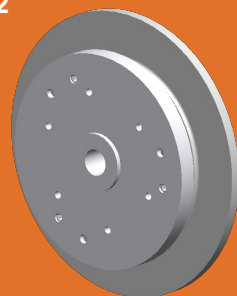

BOBINA
01348-2 - 24V

FLANGE SUPORTE
01251

FLANGE SUPORTE
01251



PORCA
01459



PARAFUSO
01298



DISCO FLUTUANTE
01252-2



PARAFUSO
01491



ARRUELA
01108



EIXOS COMPATÍVEIS

EIXOS COMPATÍVEIS:

EIXO BOMBA AT-TH
01026
01044

ROSCA
5/8"

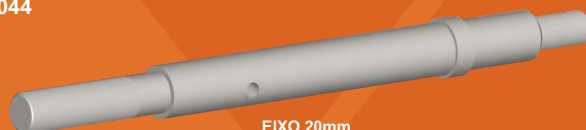

EIXO 20mm

ROSCA
1/2"



EQUIPAMENTO AGRÍCOLA

ROTORES INOX

BOMBA EÓLICA



Porto Alegre - RS
+55 51 99676-0121



Sorriso - MT
+55 66 99931-1198



Barreiras - BA
+55 77 99941-4048



Pensacola - FL
+1 850 972-9096

ROTORES INOX

ROTOR B.E GRANDE 1/2"
05096



ROTOR B.E GRANDE 5/8"
05096-5/8"



NEW



ROTOR B.E GRANDE 5/8"
PERFORMANCE
05096N-5/8"

DETALHES

ROTOR B.E GRANDE 1/2"
05096



8.5mm

ROTOR B.E GRANDE 5/8"
05096-5/8"



8.5mm

ROTOR B.E GRANDE 5/8"
PERFORMANCE
05096.R2-5/8"



10.5mm

NEW

ROSCA 1/2"



ROSCA 5/8"



ROSCA 5/8"



EIXO BOMBA AT-TH
01044
01026

EIXO BOMBA AT-TH
01883
01850

EIXO BOMBA AT-TH
01883
01850

EIXOS COMPATÍVEIS

Rotores em Aço Inox Balanceados de Alta Durabilidade.

www.travicar.com.br

22

EQUIPAMENTO AGRÍCOLA

CUBOS DE HÉLICE

BOMBA EÓLICA



Porto Alegre - RS
+55 51 99676-0121



Sorriso - MT
+55 66 99931-1198



Barreiras - BA
+55 77 99941-4048



Pensacola - FL
+1 850 972-9096

CUBOS DE HÉLICE

FREIO 160MM

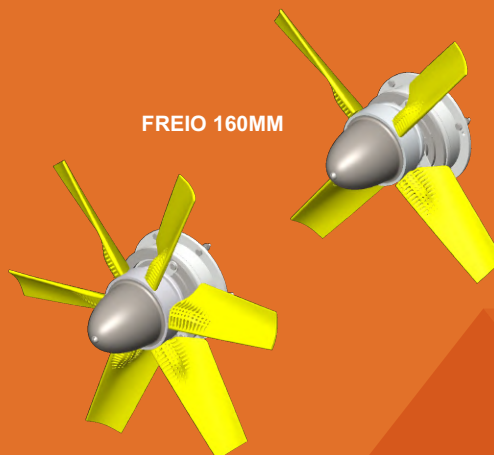

CUBOS (PITCH 6)
05137-ALTO (4 PÁS)



CUBOS (PITCH 6)
05137-ALTO (4 PÁS)

FREIO 135MM



CUBOS (PITCH 6)
05138-ALTO (6 PÁS)

CUBO DE HÉLICE
COM 6 POSIÇÕES



CUBOS (PITCH 6)
05138-ALTO (6 PÁS)

CUBO DE HÉLICE
COM 6 POSIÇÕES

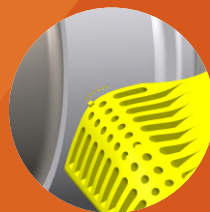

FREIO 120MM



CUBO DE HÉLICE
COM 3 POSIÇÕES

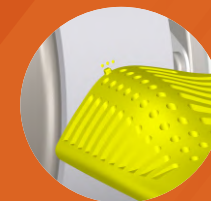

CUBOS (PITCH 3)
05138



EQUIPAMENTO AGRÍCOLA

PÁS DE HÉLICE

BOMBA EÓLICA



Porto Alegre - RS
+55 51 99676-0121



Sorriso - MT
+55 66 99931-1198



Barreiras - BA
+55 77 99941-4048



Pensacola - FL
+1 850 972-9096

PÁS DE HÉLICE

Amarelo



01065-A
145mm



01070-A
165mm



01146-A
195mm



01147-P
220mm

Vermelho



01065-V
145mm



01070-V
165mm



01146-V
195mm



01147-V
220mm

Preto



01065-P
145mm



01070-P
165mm



01146-P
195mm



01147-P
220mm

INFORMAÇÕES

Quatro opções de Medidas:
140mm / 165mm / 195mm / 220mm

Três opções de Cores:
Amarelo / Vermelho / Preto

Excelente Resistência e Maleabilidade.



EQUIPAMENTO AGRÍCOLA

FLANGES INOX

BOMBA EÓLICA



Porto Alegre - RS
+55 51 99676-0121



Sorriso - MT
+55 66 99931-1198



Barreiras - BA
+55 77 99941-4048



Pensacola - FL
+1 850 972-9096

FLANGES INOX

FLANGE DE ENTRADA 3"
90035
(AIR TRACTOR 402/502/602/802)

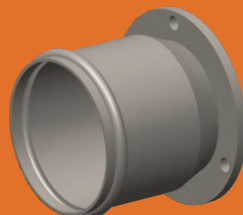

FLANGE DE SAÍDA MACHO 2"
20810
(AIR TRACTOR 402/502)

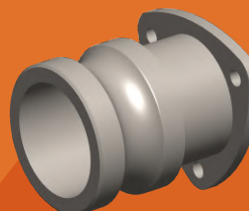

FLANGE DE SAÍDA 2"
07029
(THRUSH 510)



FLANGE DE ENTRADA 3"
07032
(THRUSH 510)



FLANGE DE SAÍDA MACHO 2 1/2"
90036
(AIR TRACTOR 602/802)

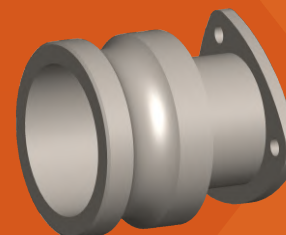



EQUIPAMENTO AGRÍCOLA

SUPORTES BOMBA EÓLICA



Porto Alegre - RS
+55 51 99676-0121



Sorriso - MT
+55 66 99931-1198



Barreiras - BA
+55 77 99941-4048



Pensacola - FL
+1 850 972-9096

SUPORTES

PORCA
01473

ARRUELA
01107

PORCA
01302

ARRUELA
01108

PARAFUSO
90059

PARAFUSO
01651



SUPOORTE B.E AT-TH SUPERIOR
90005-SUP



PINO ROSCA
E90005-INF-PRESS 5



PINO
E90005-INF-PRESS 4

PARAFUSO
01296P

ARRUELA
01107

PORCA
01473



SUPOORTE B.E AT-TH INFERIOR
90005-INF

